

HC001
S E R I E S

Camera connector for Automotive 「Coaxial Pigtail type」



Application  AUTOMOTIVE

Where to Use

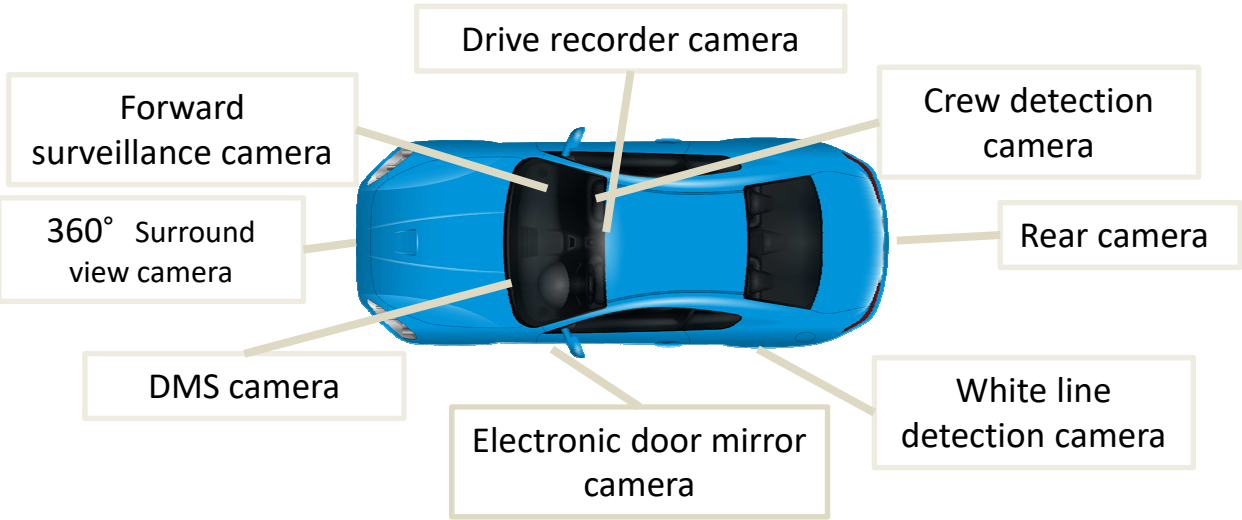

Feature

Cost reduction
by sharing camera module

Plug side connector can be selected according to the application.

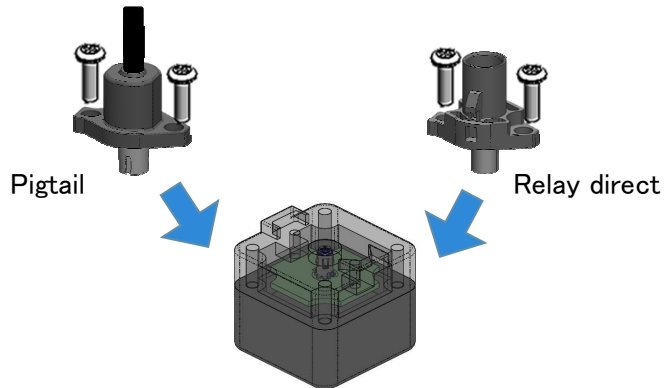

Market smallest class

Board side connector (Camera module) $\phi 3.5$



(Compared with rice grains)

Error absorption structure

mating / X,Y, θ portion : $\pm 0.3\text{mm}$

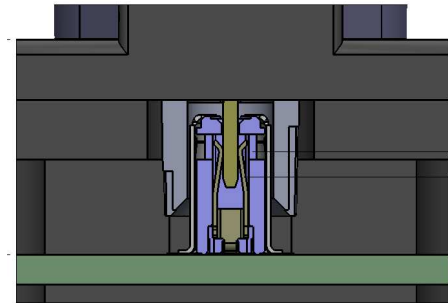

Please note that the contents may be changed without prior notice.

Structure

Board side connector

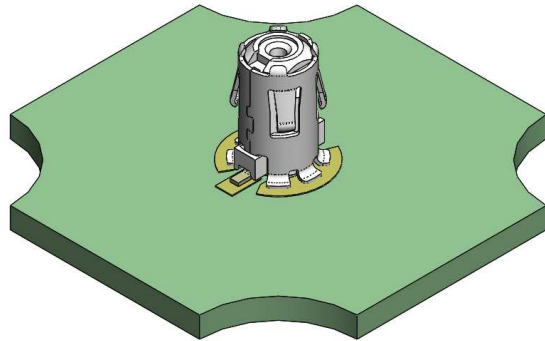

Plug side connector

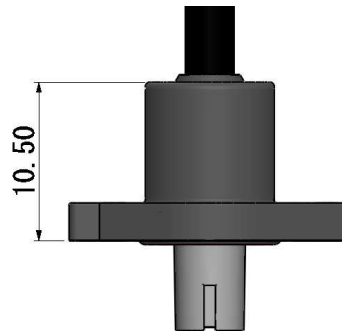

Specifications

Voltage Rating / 定格電圧	AC50Vrms
Current Rating / 定格電流	1.0A
Operating Temp. Range / 使用温度範囲	- 40°C ~ +105°C 85%RH max (Depends on useage conditions)
Mating Cycles / 挿抜耐久性	Max 20 Cycles

Transmission characteristics

VSWR

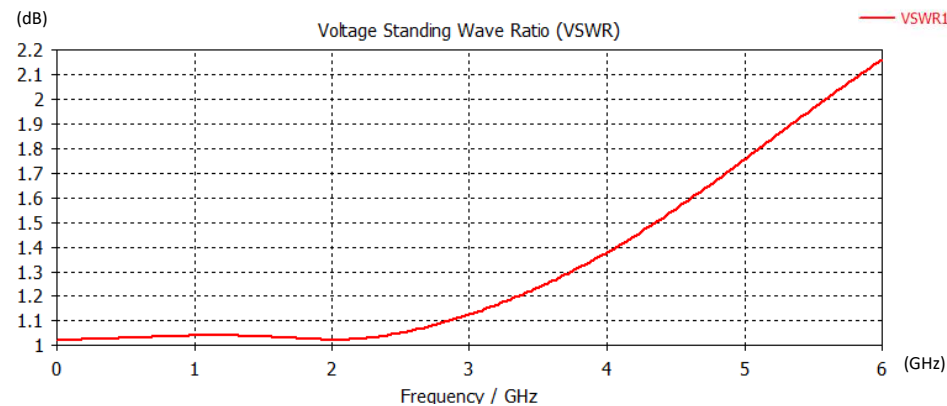

Product name

HC00X X-X001-0-VE

① ② ③

- ① Specification 1 Coaxial
 4 Differential
- ② Connector P Plug
 S Socket (Board side)
- ③ Type 0 Pigtail
 1 Relay direct